

DRIVER, TRACK & RESULTS

DRIVER	COUNTRY	WEATHER	AIR T°	TRACK T°	<input type="checkbox"/> DRY	<input type="checkbox"/> INTERMEDIATE	<input type="checkbox"/> WET
TRACK	CONDITION <input type="checkbox"/> ASPHALT <input type="checkbox"/> CARPET <input type="checkbox"/> LOW <input type="checkbox"/> MEDIUM <input type="checkbox"/> HIGH <input type="checkbox"/> BUMPY <input type="checkbox"/> SMOOTH						
RACE	DATE	QUALIFICATION	BEST LAP TIME		FINAL		

FLEX CONFIGURATION

CHASSIS ALU CARBON

CENTER SHOCK ABSORBER

OIL _____ REBOUND _____

PISTON

SPRING 6.5 8 10 12 14 16 18

OTHER _____

CENTER TUBES

OIL _____

FRONT TYRES Controlled Tyre REAR

RUBBER TYPE FOAM

BRAND & TYPE _____

DIAMETER (mm) _____

ADDITIVE _____

ADDITIVE TIMING (min) _____

SURFACE (%) _____

ELECTRONICS

BATTERY _____

MOTOR _____ TIMING _____

ESC _____ RECEIVER _____

SERVO _____ RADIO _____

RATIO CONFIGURATION

PINION _____ SPUR GEAR _____ PITCH _____

FINAL RATIO _____ ROLLOUT _____ mm

AERODYNAMIC CONFIGURATION

BODY _____

FRONT WING

FRONT BIG WING FLAPS YES NO

FRONT SMALL WING FLAPS YES NO

REAR WING

REAR WING POSITION UP MIDDLE DOWN

REAR DIFFUSER YES NO

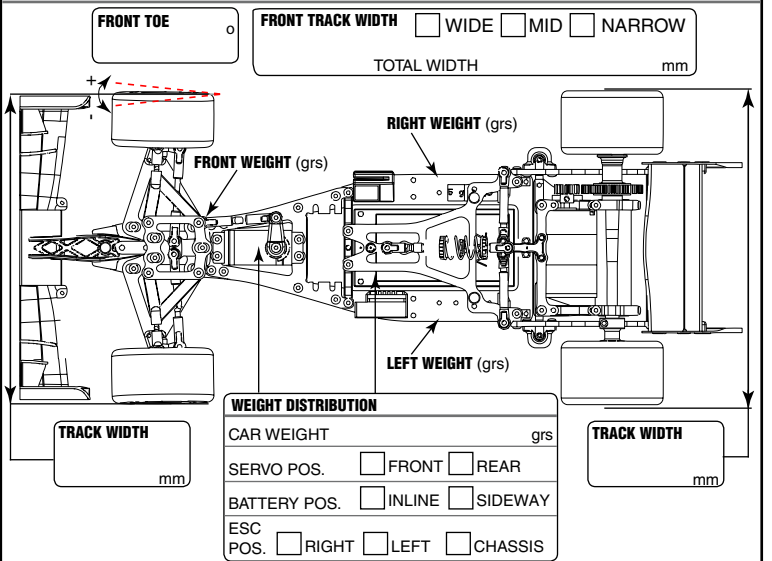
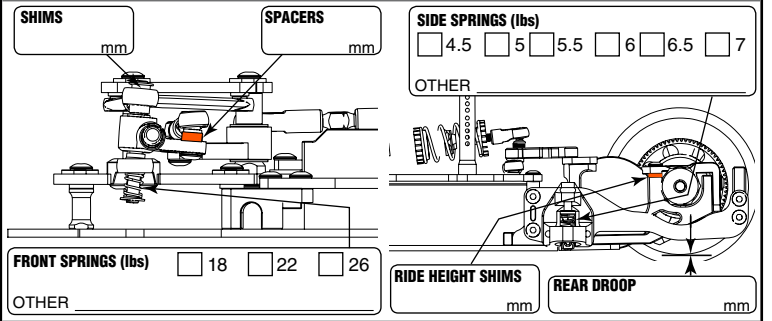
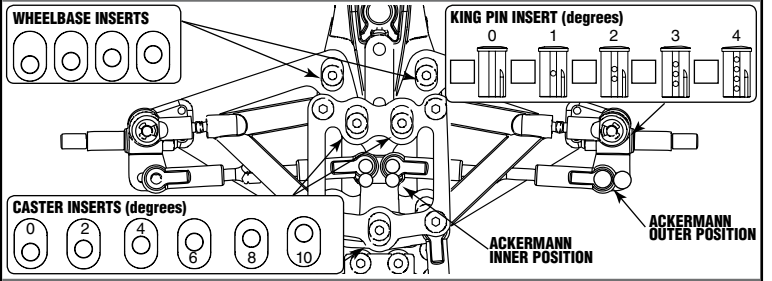
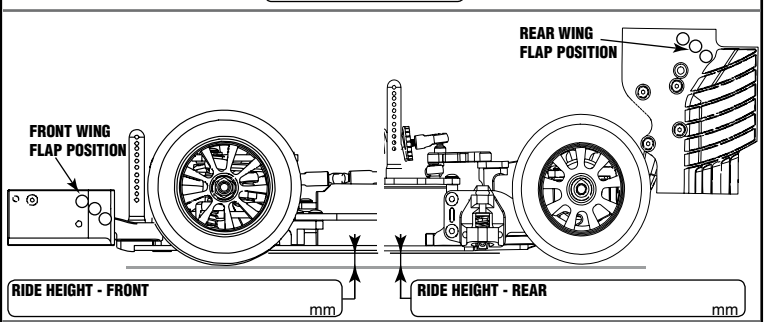
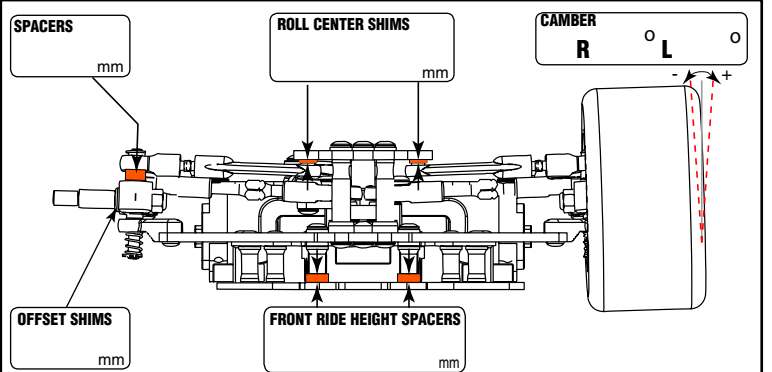

Arr0 - PetitRC

NOTES