

## DRIVER & TRACK

DRIVER **JUAN HIDALGO** DATE **JUL 25**

TRACK **AIGEN** GRIP **MEDIUM**

1ST **SPUR GEARS** 2ND

61  62  63  56  57  58

1ST **PINION** 2ND

18  19  20  23  24  25

FR **SHOCK ABSORBERS** RR

OIL **500** cst OIL **800** cst

SPRINGS **8.0** SPRINGS **5.7**

PISTON PISTON

## HEAVE DAMPER

FR **HEAVE DAMPER**  RR

OIL cst OIL cst

SPRINGS SPRINGS

PISTON PISTON

## ANTI-ROLL BARS

FRONT **2** REAR **3**

## FR TYRES

Controlled Tyre  RR

MAKE & TYPE **MATRIX**

SHORE

mm DIAMETER mm

## POWER PACK

ENGINE

BRAND & TYPE **NOVA**

GLOWPLUG **7** CARB Ø **9**mm

EXHAUST

PIPE MANIFOLD

FUEL

BRAND **ENERGY** NITRO % **16**

## CLUTCH

CLUTCH  ALU  STEEL **CLUTCH SHOE** **YELLOW**

CLUTCH SPRING

CLUTCH BELL GAP **0,7**mm

## AERODYNAMIC CONFIGURATION

BODY BRAND **XTREME** BODY POSITION **PRECUT** mm

BODY TYPE **HYPER**

BUMPER TYPE

AIR TRIM POS. **10** mm

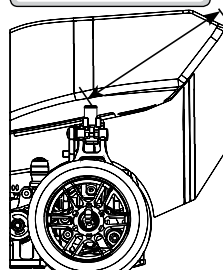

## REMARKS

15gr IN THE LEFT SIDE OF CHASSIS IN FRONT OF LEFT RADIO TRAY BRACKET.  
RIDE HEIGHT WITH HUDY STATION (14,7-13) SERVO SAVER ACKERMANN INSERT FROM STAR RC OF 9mm

## REAR SETUP

REAR BODYMOUNT POSITION

STANDARD  CARBON

SHOCK SHIMS **3**mm

CAMBERLINK POSITION

ROLL CENTER INSERT FRONT REAR

REAR CAMBER **R 3,5°** **L 3°**

OFFSET **1**mm

RIDE HEIGHT mm WITH TYRE Ø mm

DOWN STOP **8**mm

RR TRACK WIDTH **260**mm

UPPER LINK HEIGHT

UPRIGHT INSERT  MID  LOW

REAR REACTIVE STEERING SYSTEM

REAR TOE **-3°**

WHEEL BASE  0  1  2  3

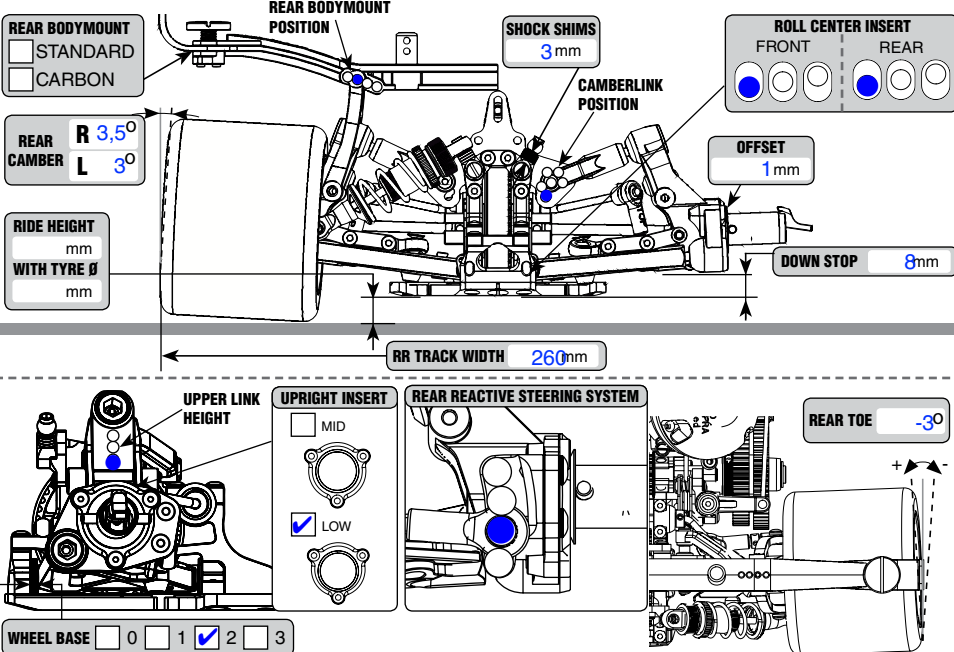

## FRONT SETUP

FRONT CAMBER **R 2°** **L 2°**

SHOCK SHIMS **2**mm

ROLL CENTER FR **1**mm RR **1**mm

UPPER ARM INSERT

OFFSET SHIMS **0,5**mm

RIDE HEIGHT mm WITH TYRE Ø mm

FR TRACK WIDTH **250**mm

SUSPENSION BRACKET  NARROW  WIDE

SHOCK BRACKET  WIDE  NARROW

OFFSET **1,3**mm

DOWN STOP **1**mm

STEERING BLOCK INSERT

ACKERMANN INSERTS

FRONT TOE **1,5°** CASTER **3**mm

SHIMS **2**mm

STEERING BLOCK LEVERS  OPT. 1  OPT. 2

WHEEL BASE  0  1  2  3  4

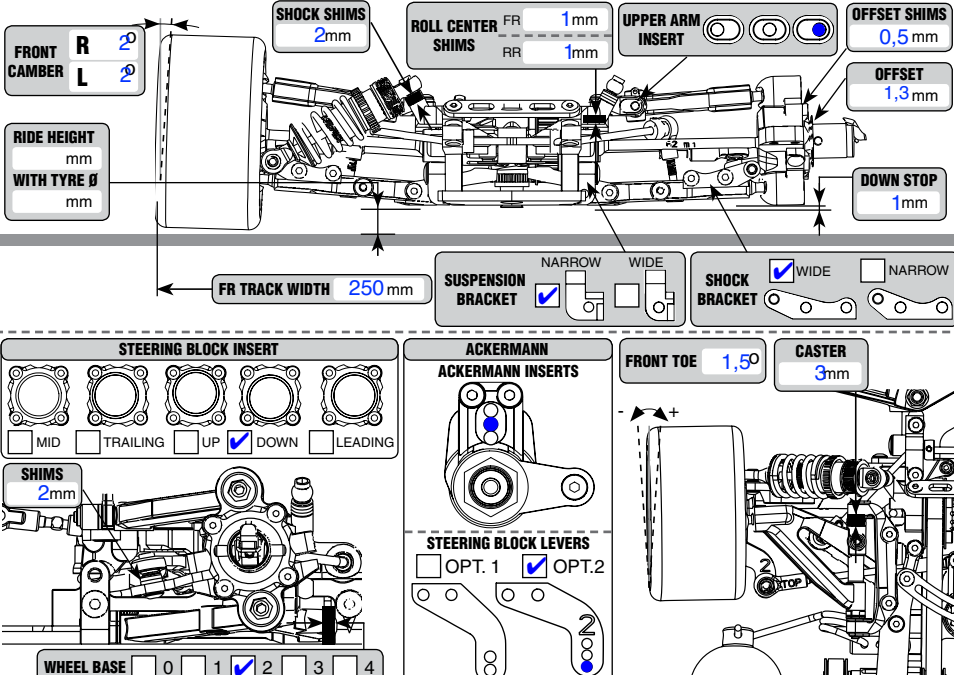

## FLEX SETUP

FR RADIO PLATE FLEX  STIFFENER (3 SCREWS)  NO STIFFENER (2 SCREWS)  NO STIFFENER & NO SCREWS

CENTER LINK  NO  YES

CENTER STIFFENER  NO  YES

SHOCKMOUNT BRACE  YES  NO

REAR FLEX  STIFF  FLEX

SHOCKMOUNT BRACE  YES  NO

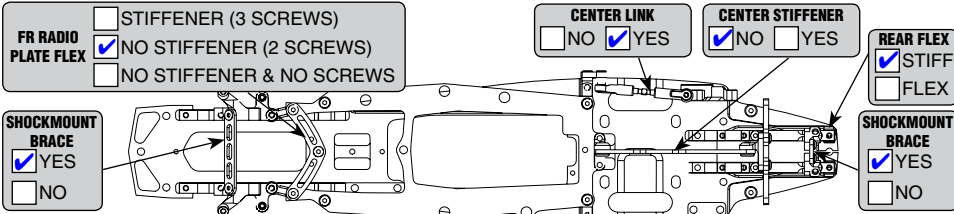

## WEIGHT DISTRIBUTION

FRONT WEIGHT **5**grams mm  MID WEIGHT  CENTRAL WEIGHT grams mm

RIGHT RADIO TRAY BRACKET  ALU  BRASS

OPTION BATTERY PLATE  CARBON  BRASS EXTRA WEIGHTS

LEFT **15**grams  RIGHT **15**grams

TOTAL CAR WEIGHT **2360**grams  ALU  BRASS

LEFT RADIO TRAY BRACKET  ALU  BRASS

RR WEIGHT

