

DRIVER, TRACK AND RESULTS

DRIVER Default setup COUNTRY WEATHER AIR TEMP 32 TRACK TEMP DRY INTERMEDIATE WET

TRACK TRACTION LOW MEDIUM HIGH COMMENTS

RACE DATE QUALY POS. QUALY TIME STARTING POS. FINAL POS.

FRONT SHOCK ABSORBERS		REAR	
2000 cst	OIL		1000 cst
Black/37 lbs	SPRINGS	White/31.5 lbs	
	mm REBOUND		5 mm
N° HOLES 6	Ø 1.2 mm	PISTONS N° HOLES 6	Ø 1.2 mm
<input checked="" type="checkbox"/> STRAIGHT <input type="checkbox"/> ANGLED	HOLES TYPE	<input checked="" type="checkbox"/> STRAIGHT <input type="checkbox"/> ANGLED	
<input checked="" type="checkbox"/> BLADDER <input type="checkbox"/> EMULSION	SEAL TYPE	<input checked="" type="checkbox"/> BLADDER <input type="checkbox"/> EMULSION	

ANTI-ROLL BARS	
FRONT ANTI-ROLL BAR	1.8 mm
REAR ANTI-ROLL BAR	2.5 mm

DIFFERENTIALS	
FRONT DIFF	REAR DIFF
<input checked="" type="checkbox"/> HTD <input type="checkbox"/> STD	<input checked="" type="checkbox"/> HTD <input type="checkbox"/> STD
200,000 cst	100,000 cst

GEARING	
PINION	17 Teeth
SPUR GEAR	44 Teeth

ELECTRONICS	
BATTERY	
BRAND <input type="text"/>	CAPACITY <input type="text"/> mAh
MOTOR	
BRAND DragonRC	TYPE HW-8 2000KV
ESC	
BRAND DragonRC	TYPE HW-8 6S/150A WP

ELECTRONICS LAYOUTS			
<input type="checkbox"/> 3S STICK BATTERIES	<input checked="" type="checkbox"/> 2S STICK BATTERIES	<input type="checkbox"/> 2S SHORTY REARWARD BATTERIES	<input type="checkbox"/> 2S SHORTY FORWARD BATTERIES

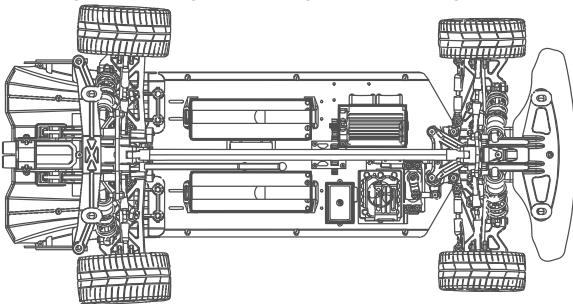

FRONT TIRES		REAR	
Kit	MAKE	Kit	MAKE
	TYPE		TYPE
	INSERTS		INSERTS
	WHEELS		WHEELS

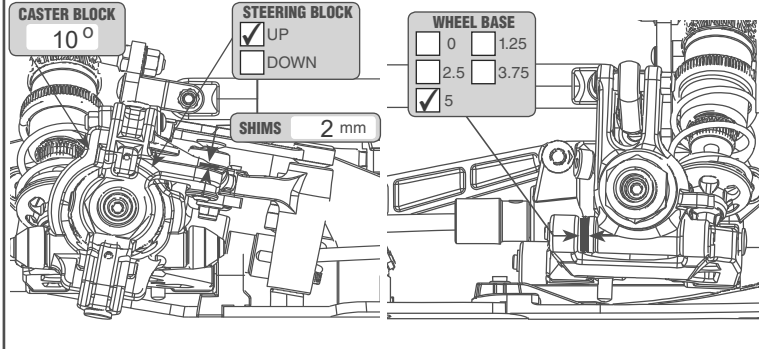
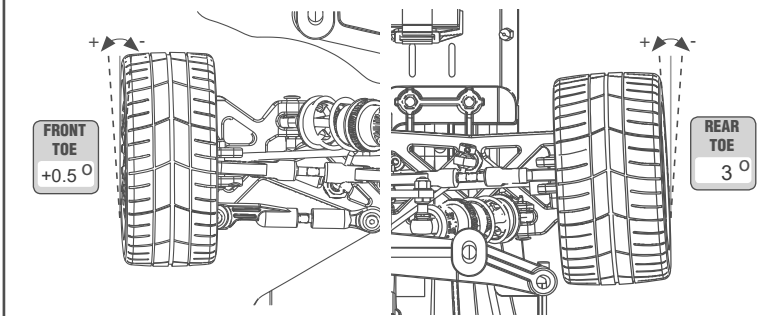
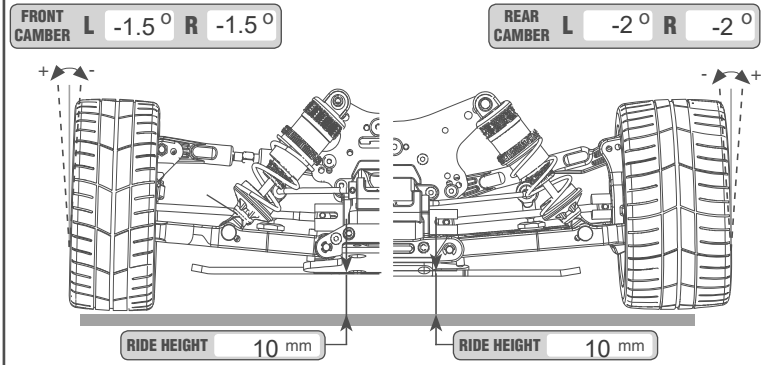
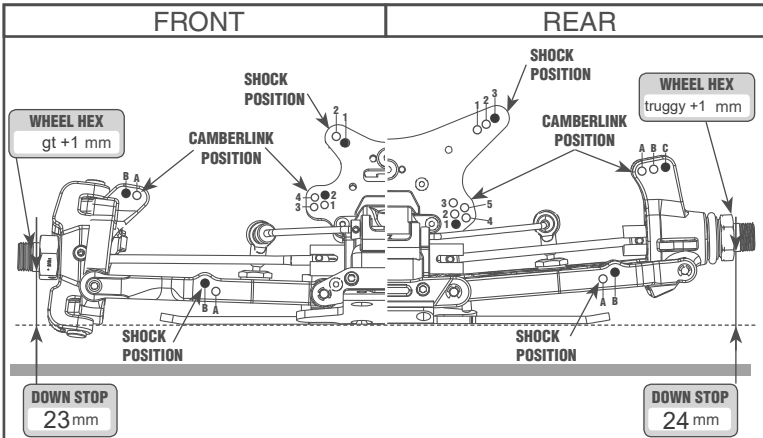

REMARKS