

STEP 1

Change to new parts

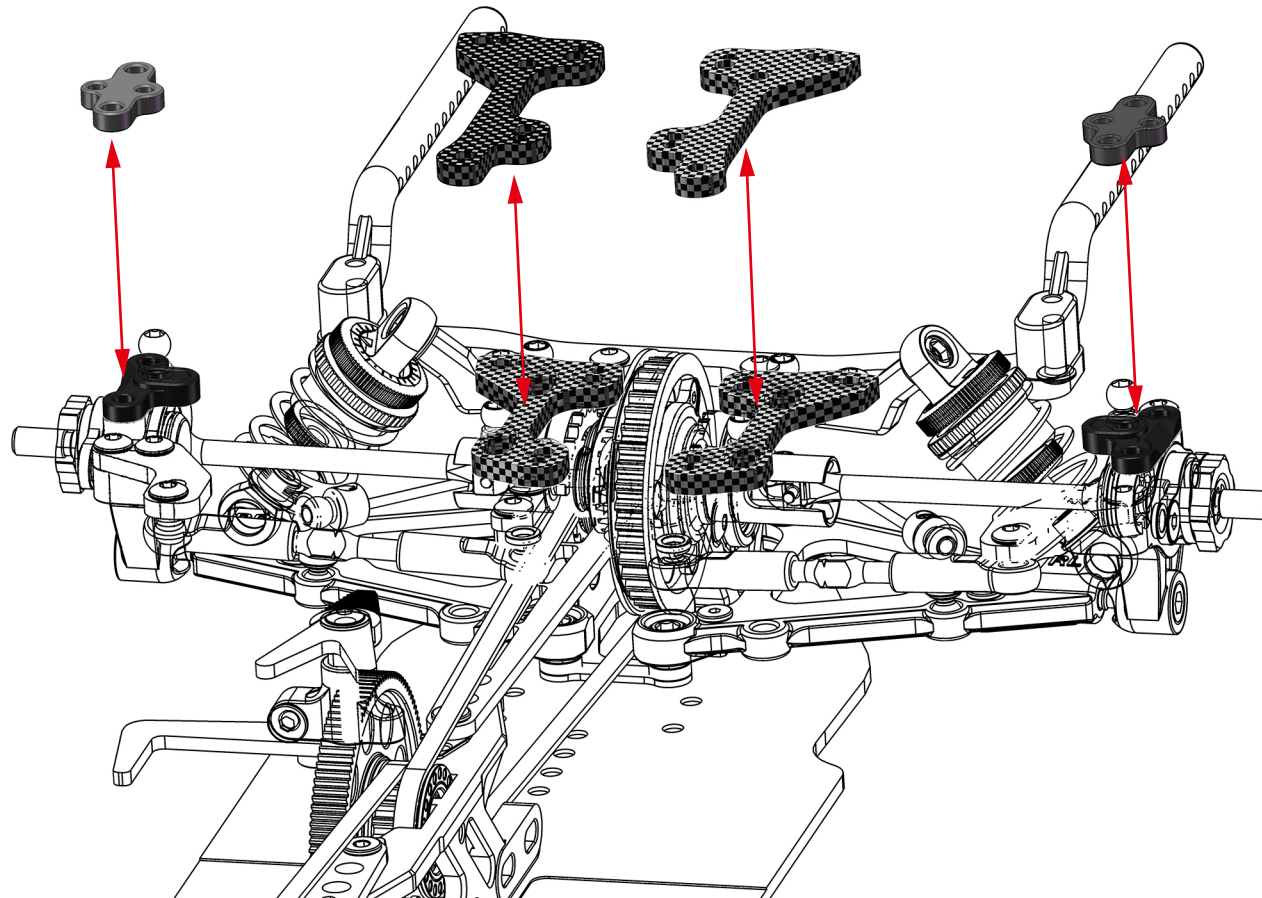

STEP 2

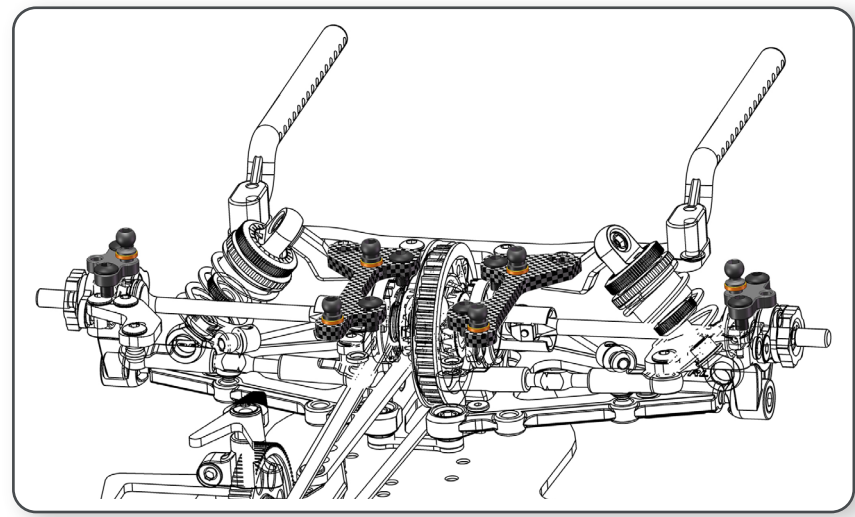
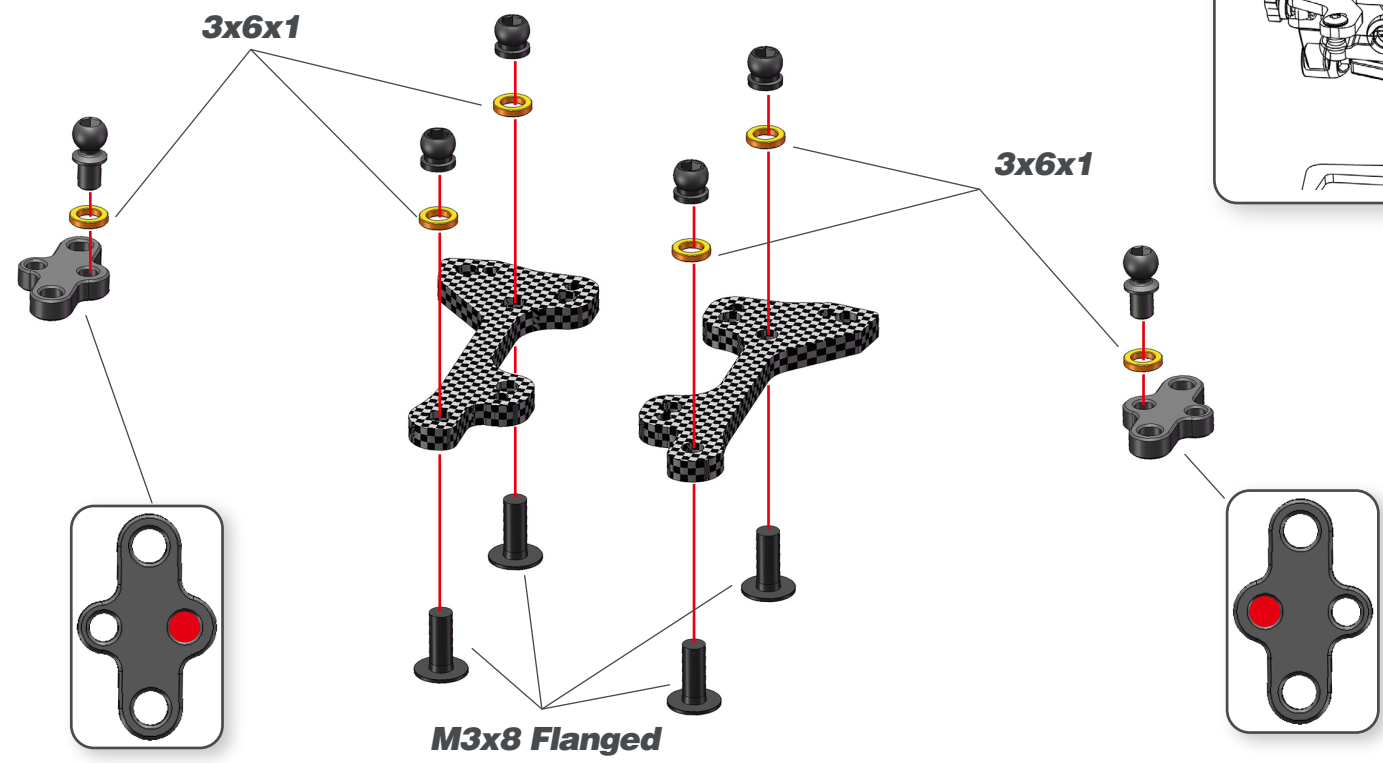

STEP 3

3.1 X2 FRONT AND REAR

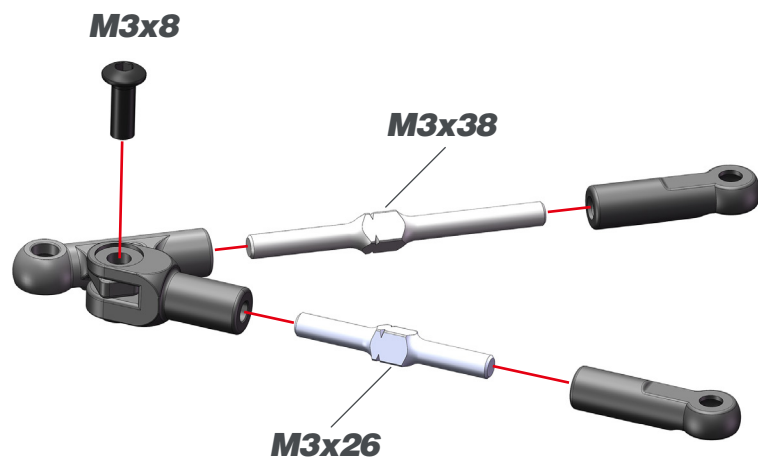

3.2 X2 FRONT AND REAR

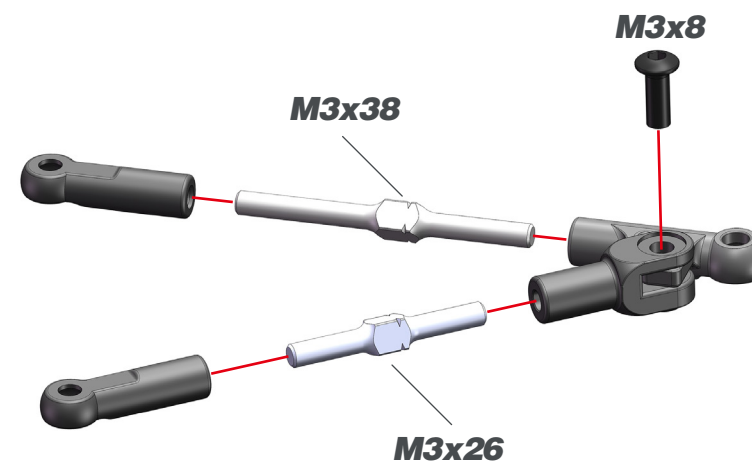

STEP 4

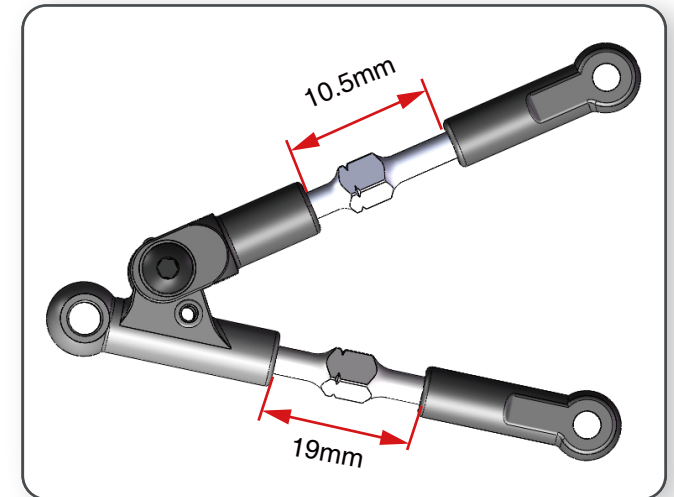
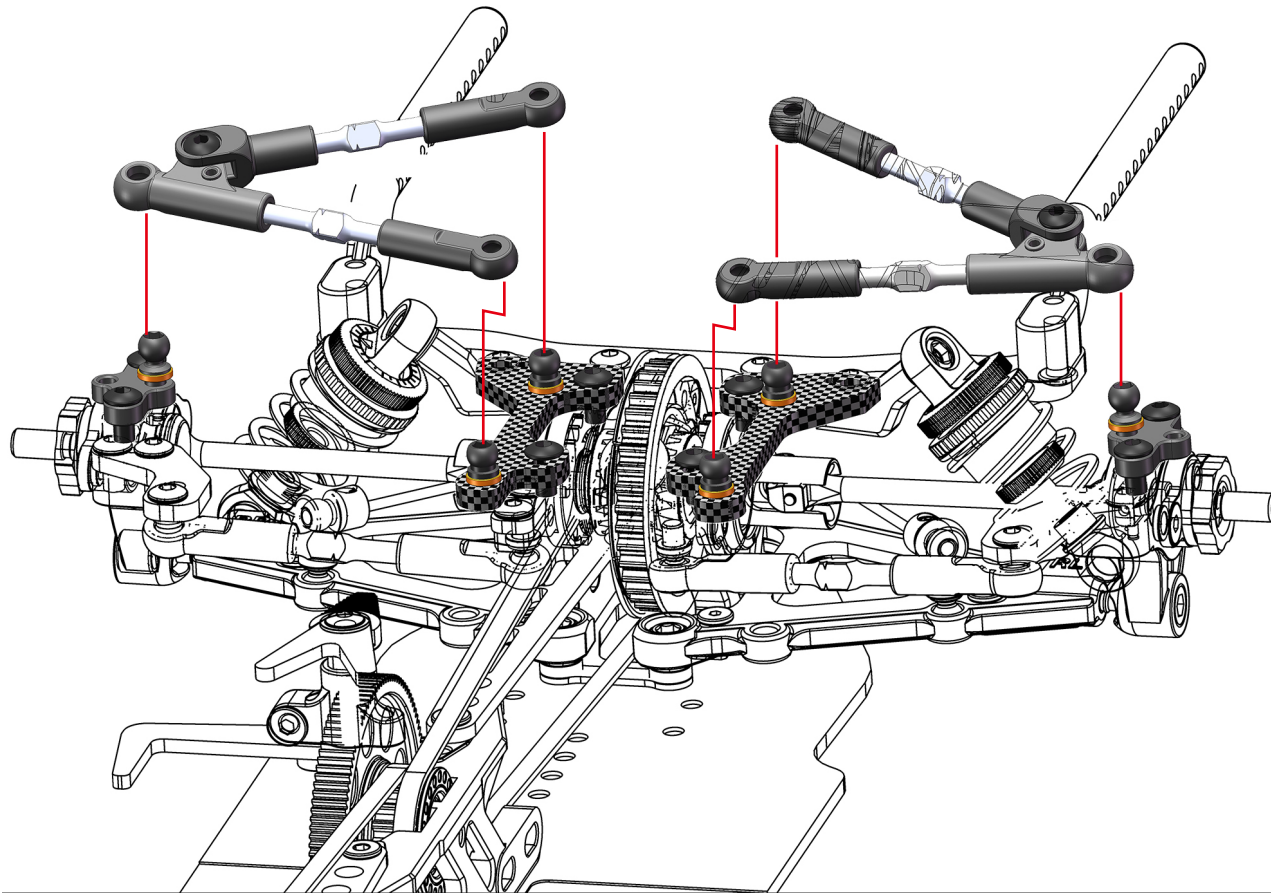

STEP 5

Change to new parts

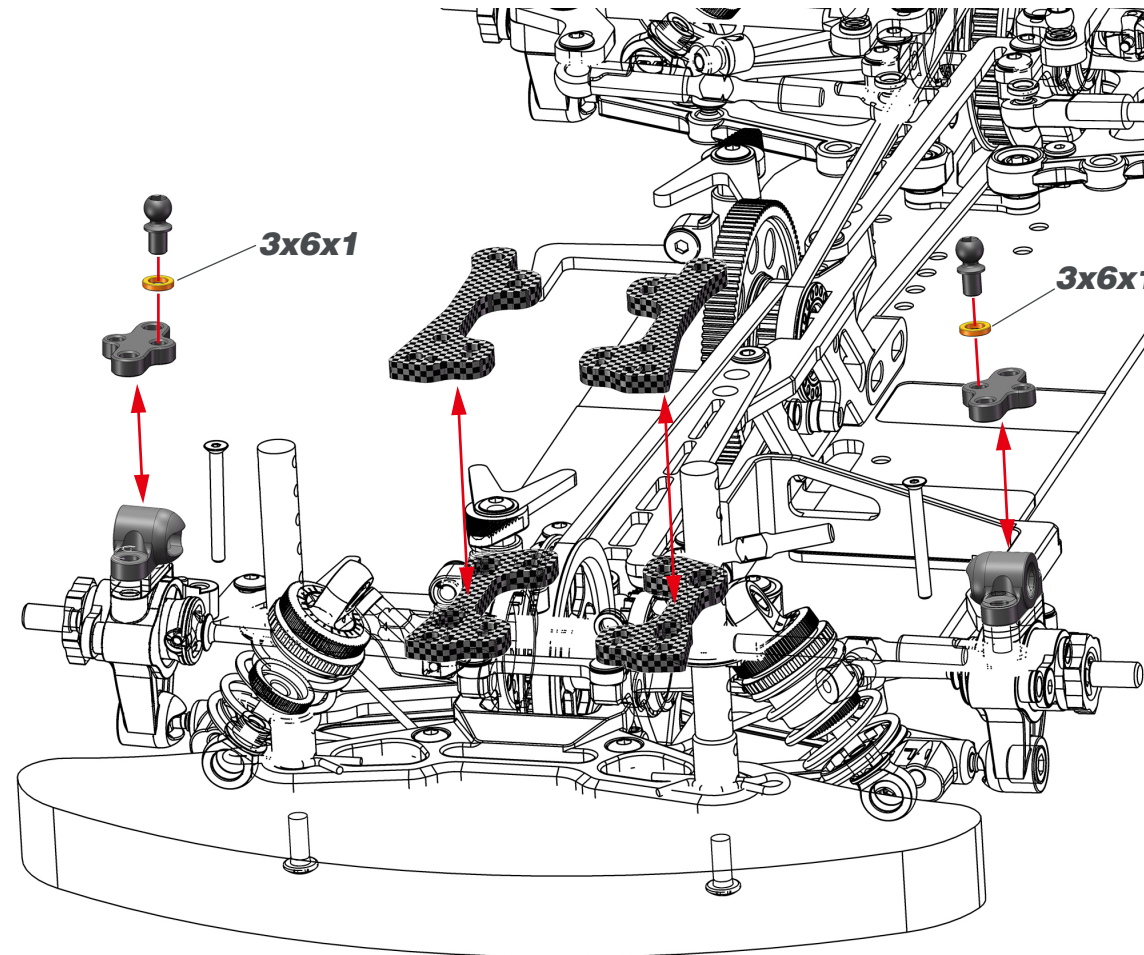

STEP 6

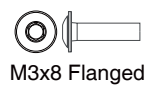
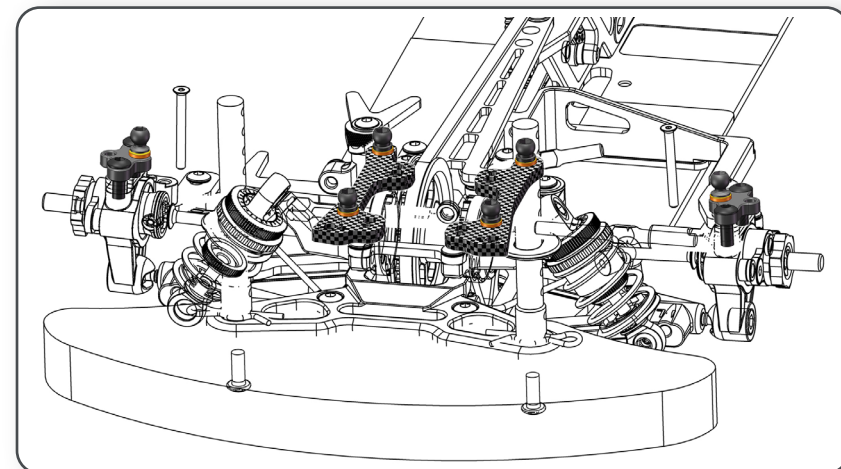
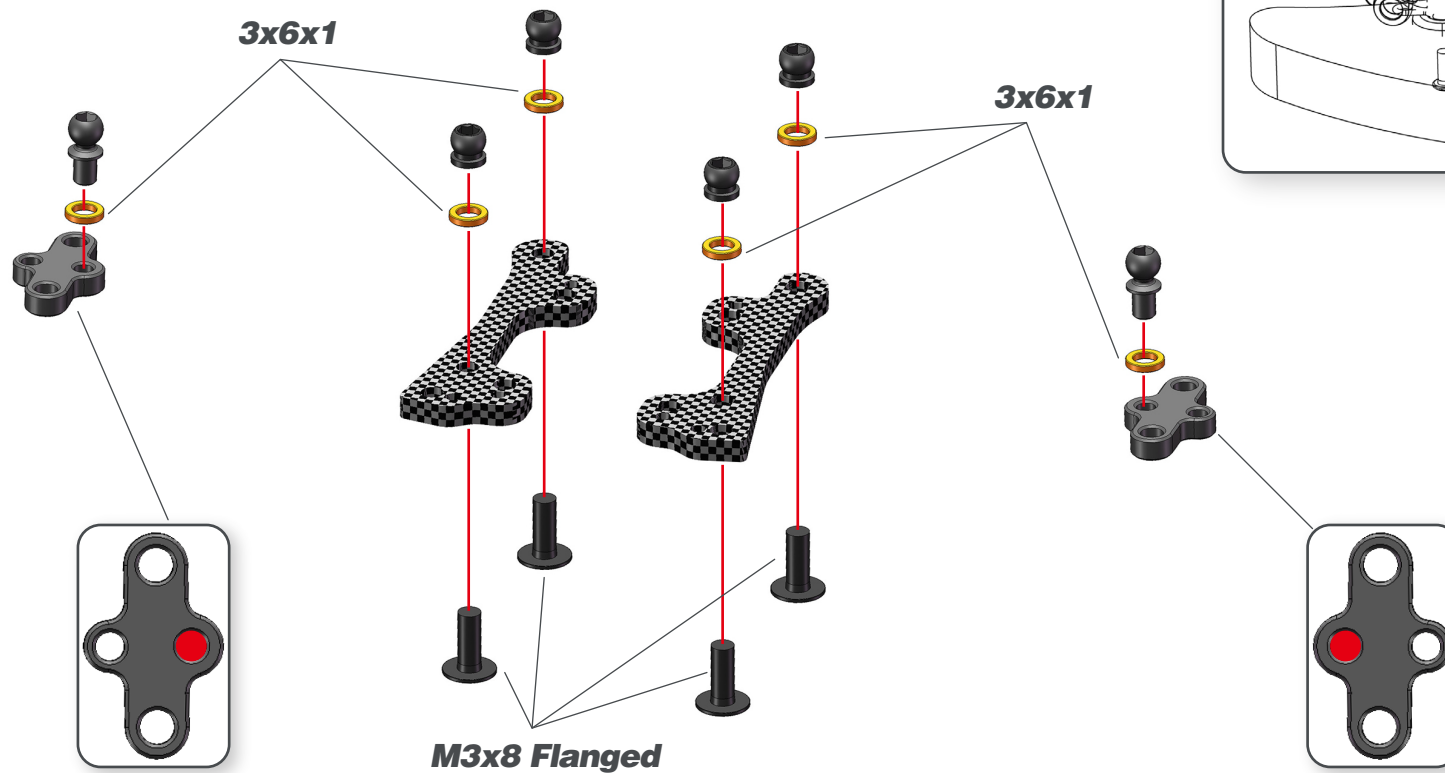

STEP 7

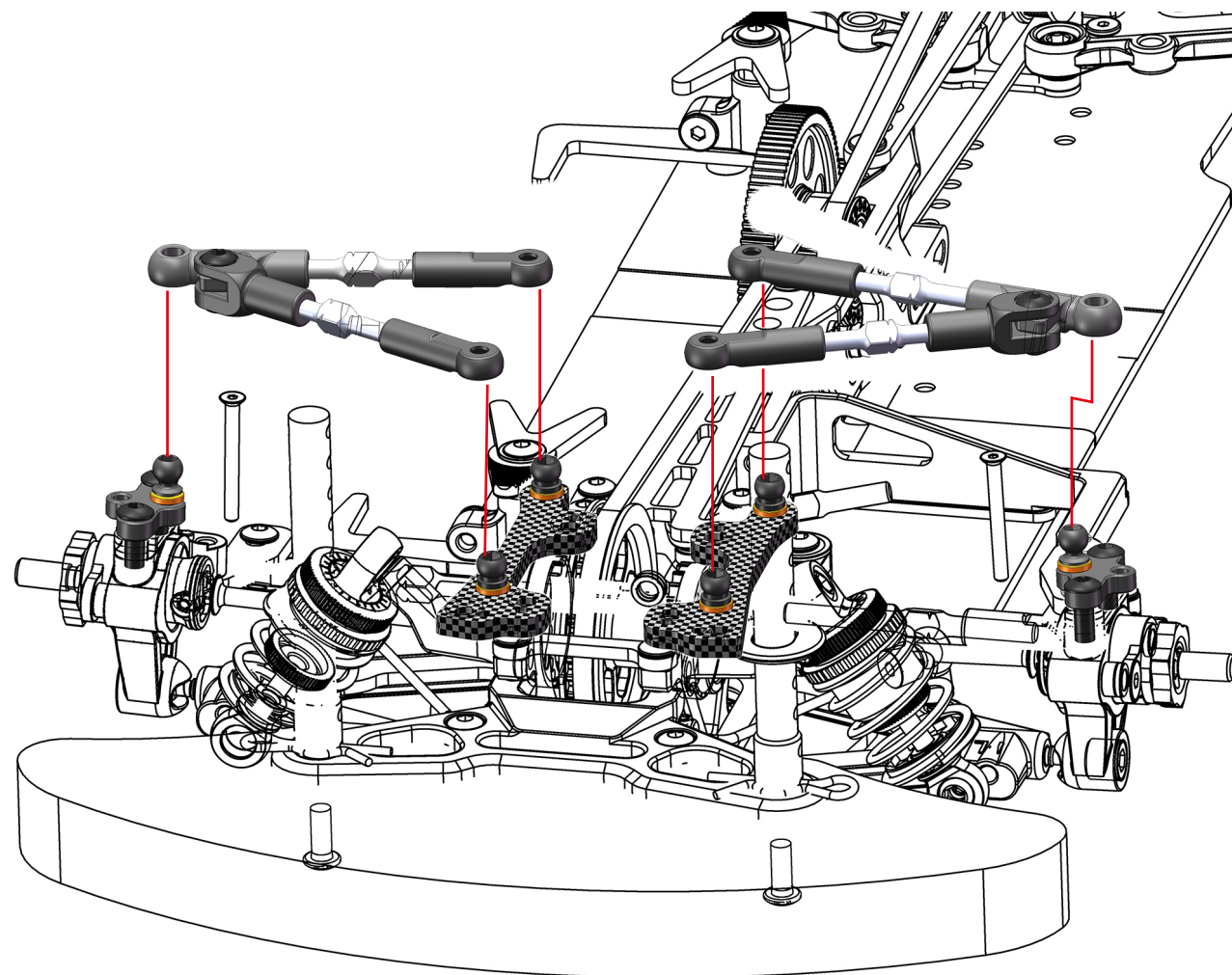
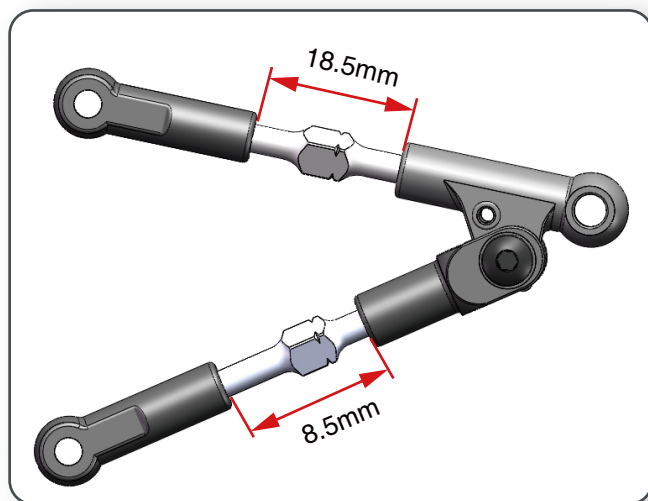

**FRONT LEFT
UPPER ARM**

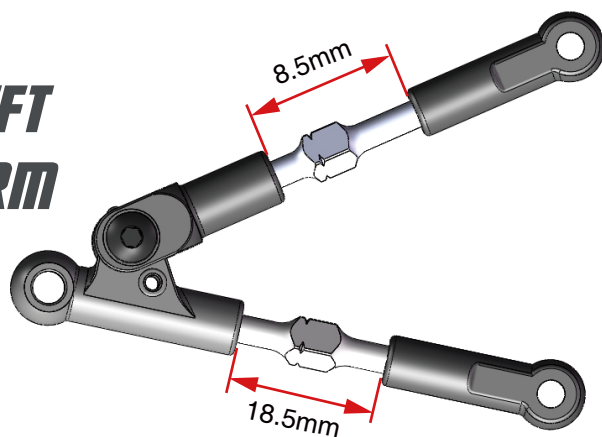

**FRONT RIGHT
UPPER ARM**

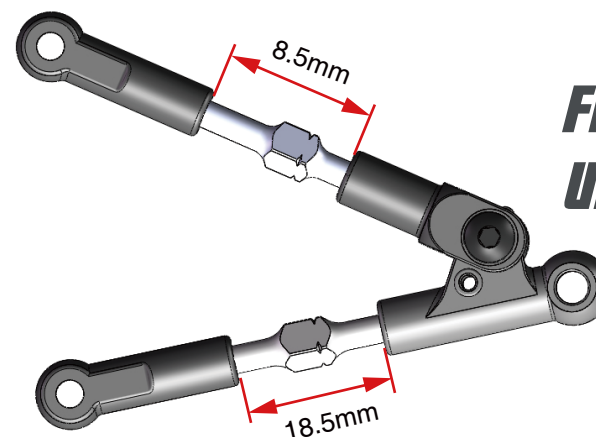

**REAR LEFT
UPPER ARM**

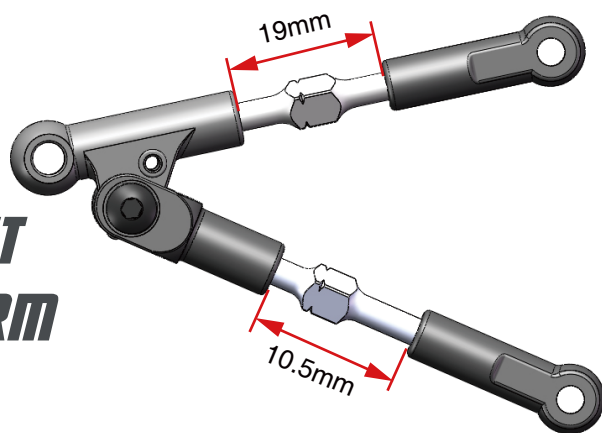

**REAR RIGHT
UPPER ARM**

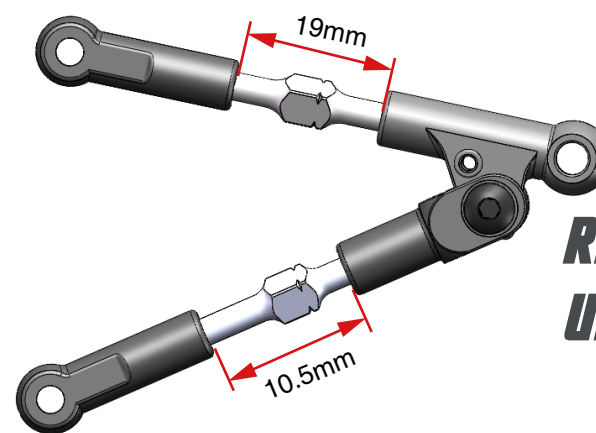

Notes: This basic setup is 2 degree camber for front and rear, 4 degree caster for front and -4 for rear.

CAMBER ADJUSTMENT

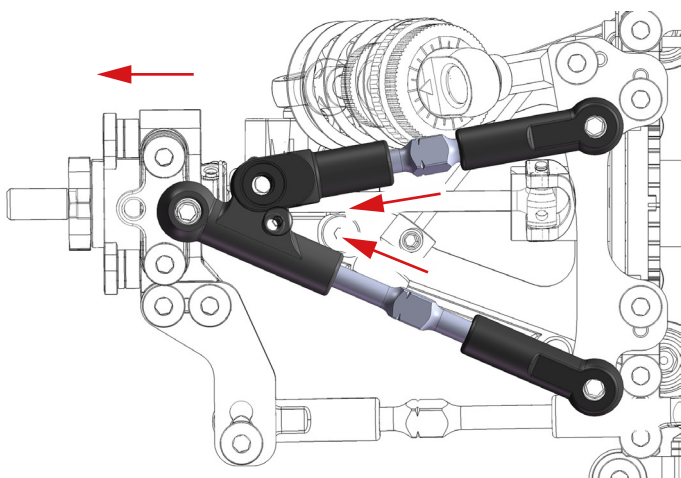
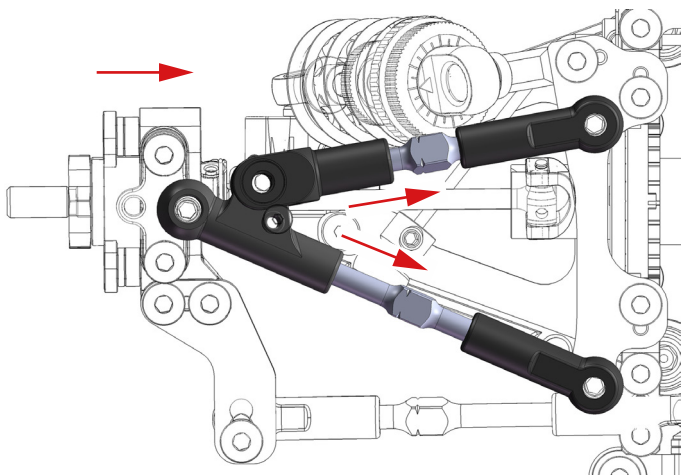

CASTER ADJUSTMENT

